

ITS-3400 *Vibration Testing System*



System Overview

ITS-3400 Electro-dynamic vibration testing system is consisted of shaker, amplifier, slip table (optional), Head expander (optional), vibration controller, accelerometer, etc. It can accomplish tests of sine, random, shock, mixed, road simulation, etc.

ITS-3400 Electro-dynamic vibration testing system possess the advantages of wide frequency band, outstanding indexes, high reliability, small occupation space, high mobility, and user-friendly, etc. Its standard vibration simulation has wide application in military, auto parts, electronics, household appliances, transportation, etc.

Features

- ◆ Top and bottom guide rollers structure, strong resistance to overturn, good guidance quality, wide working frequency band
- ◆ Central airbag support the structure, high support capacity.
- ◆ Air spring trunnion vibration isolation structure reduces the resonance of the shaker.
- ◆ “dual magnetic circuit” structure reduce the magnetic leakage, increase the evenness of the magnetic field
- ◆ Full protection function, easy for maintenance.
- ◆ Well designed air cooling system, low noise.



ITS-3400

ITS-3400			
Max. Sine Force	3,400kgf (7496lbf)	Max. Random Force	2,380kgf (5247lbf)
Frequency range	2-2000Hz	Equivalent mass of moving parts	34kg (74.96lbs)
Max displacement (p-p)	51mm (2in)	Load joint	8 \varnothing 160mm (6.30in) , 8 \varnothing 250mm (9.84 in)
Max speed	2m/s (78.7in/s)	Table bolt	M10
Max acceleration	981m/s ² (100g)	Magnetic leakage	< 1mT
First order resonance frequency	3000Hz	(L*W*H) overall dimension	1200mm*860mm*1150mm 47.24in*33.86in*45.28in
Max load	500kg (1102lbs)	Shaker weight (without package)	3000kg (6613.87lbs)
Vibration isolation frequency	<3Hz	Cooling	Air cooling
Table diameter	\varnothing 320mm (12.60 in)		

VSA-H303 Amplifier parameters		PBL-3 Blower parameters	
Max output power	40kVA (48A)	Blower power	15kW
Rated output voltage	120Vrms	Blast capacity	0.66m ³ /s (23.31ft ³ /s)
SNR	> 65dB	Blast pressure	0.075kgf/cm ² (1.07psi)
Efficiency of the amplifier	> 93%	Diameter of air duct	200mm (7.87in)
Dimensions of amplifier (L*W*H)	800mm*900mm*2100mm (31.50in*35.43in*82.68in)	Dimensions of blower(L*W*H)	1050mm*897mm*1970mm (41.34in*35.21in*77.56in)
Amplifier weight (without package)	520kg (1146.40lbs)	Blower weight(without package)	320kg (705.48lbs)

Environment requirement		Optional configuration	
Temp	0-40°C (32-104F)	Slip table	Head expander
Humidity	0%-90%RH, no frost	Moving parts	Heat isolation board
Power requirement	3phase 480V \pm 10%, 60Hz, 26kVA (31A)	Fixture	
Requirement of pressing air	0.6MPa (87.02psi)		

ITS-3400 Dimension Diagram

Vertical mode diagram

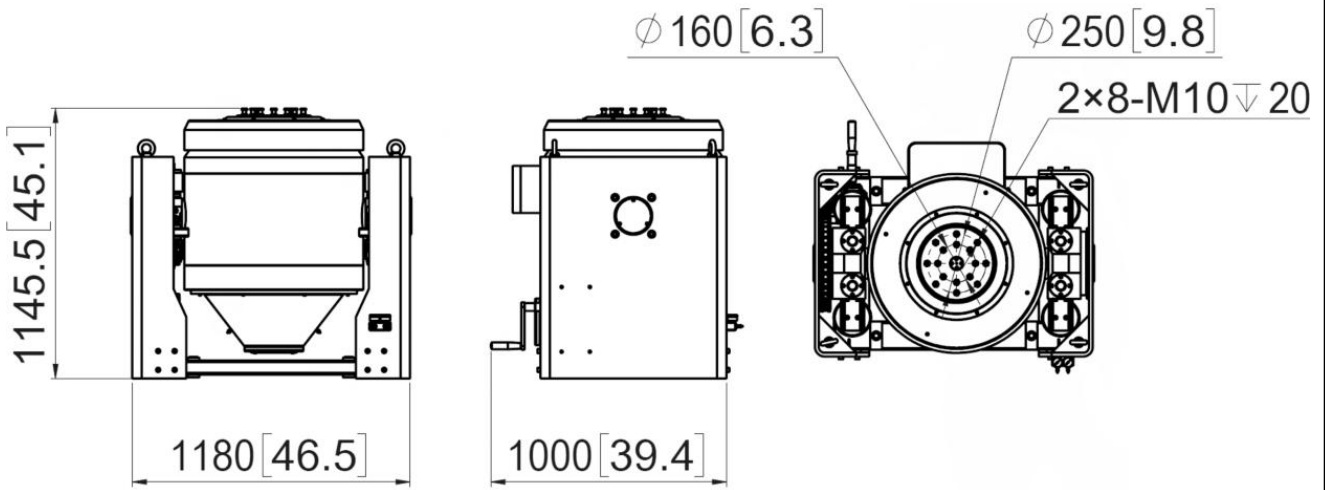

Horizontal mode diagram

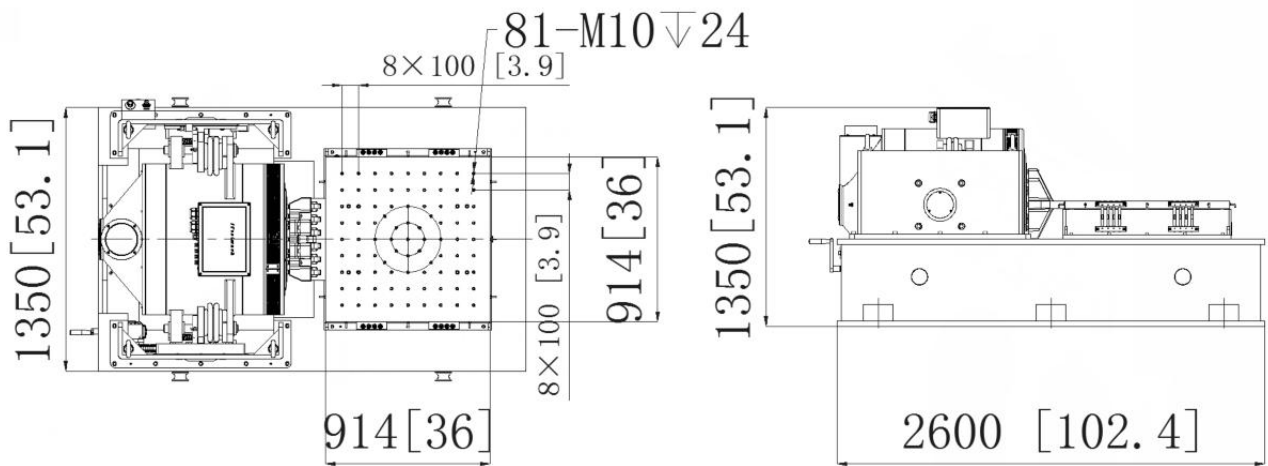

Table, amplifier and blower

